

GFXTERMO4



4-ZONE MODULAR CONTROLLER

Stand-alone unit for independent control of four PID process loops.
Power supply 24VDC ± 25%.

- Inputs: TC, RTD, mA, VDC
- 4 logic outputs for SSR
- 2 configurable alarms
- DIN rail attachment



Modbus_{RTU}

PROFIBUS

PROFINET

CANopen

EtherCAT

DeviceNet

EtherNet/IP

logic / communication

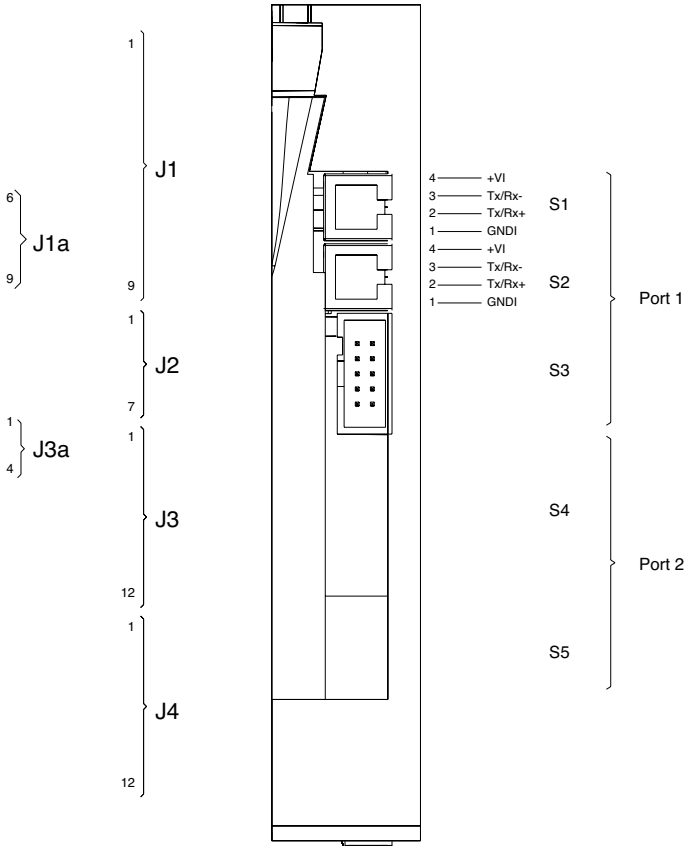
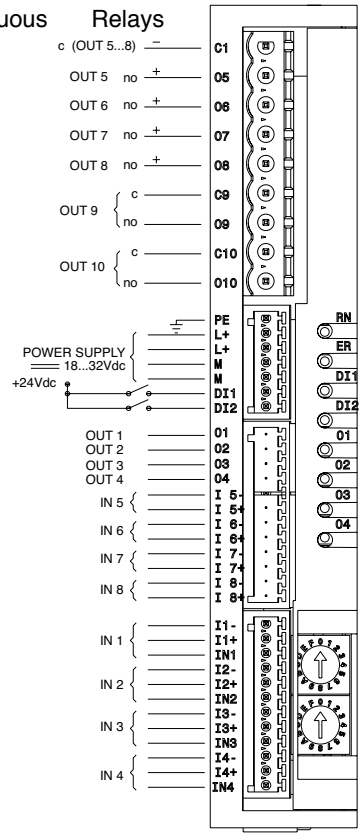
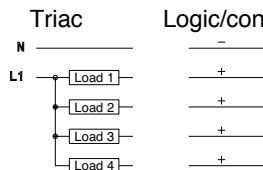

CE UL

Réglage	Special functions	Serial Communication	Order code	SAP/METEL code	
Hot	2 digital inputs	Modbus RTU (slave)	GFXTERM04-0-0-0	F030922	A
Hot + Cold	2 digital inputs + 4 TC inputs	Modbus RTU (slave)	GFXTERM04-R-1-0	F029790	A
Hot + Cold	2 digital inputs + 4 TC inputs	N. 2 Modbus RTU (slave)	GFXTERM04-R-1-M	F033048	
Hot + Cold	2 digital inputs + 4 TC inputs	Profibus DP (slave)	GFXTERM04-R-1-P	F036208	
Hot + Cold	2 digital inputs + 4 TC inputs	CANopen (slave)	GFXTERM04-R-1-C	F032855	